

Specifications

MODELS	Model S-120		S-125	
	Metric	US	Metric	US
Working height	38.4 m	126 ft	39.9 m	131 ft
Platform height	36.6 m	120 ft	38.1 m	125 ft
A Height - stowed	3.07 m	10 ft 1 in	3.07 m	10 ft 1 in
B Length - stowed	12.2 m	39 ft 11 in	12.2 m	39 ft 11 in
Width axles retracted	2.6 m	8 ft 6 in	2.6 m	8 ft 6 in
C Width axles extended	3.5 m	11 ft 6 in	3.5 m	11 ft 6 in
D Wheelbase	3.66 m	12 ft	3.66 m	12 ft
E Ground clearance	28 cm	11 in	28 cm	11 in
F Platform length	91 cm	36 in	91 cm	36 in
G Platform width	2.44 m	96 in	2.44 m	96 in
Horizontal reach max.	22.9 m	75 ft	24.4 m	80 ft

RANGE OF MOTION

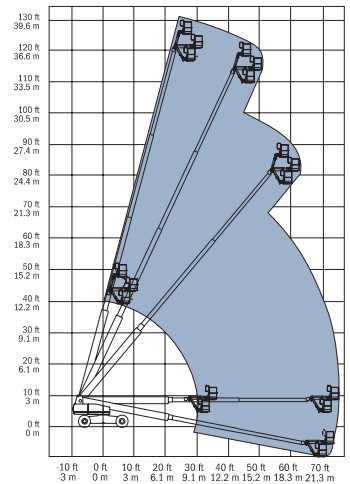

PRODUCTIVITY				
Lift capacity	340 kg	750 lb	227 kg	500 lb
Turning radius - outside retracted axles 4-wheel steer	3.2 m	10 ft 6 in	3.2 m	10 ft 6 in
Turntable rotation	360° continuous		360° continuous	
Turntable tailswing	1.68 m	5 ft 6 in	1.68 m	5 ft 6 in
Controls	proportional		proportional	
Platform rotation	160° hydraulic		160° hydraulic	
Drive speed, stowed	4.8 km/h	3 mph	4.8 km/h	3 mph
Gradeability, stowed	40%		40%	
Tyres	18 x 22.5, 18 pr, FF		18 x 22.5, 18 pr, FF	

POWER				
Power source	Deutz BF4L 2011 4 cylinder Diesel 78 hp (58 kW)			
Auxiliary power unit	12V DC		12V DC	
Hydraulic tank capacity	208 litre	55 gal	208 litre	55 gal
Fuel tank capacity	151 litre	40 gal	151 litre	40 gal

WEIGHT				
Weight**	20,112 kg	44,340 lb	20,248 kg	44,640 lb

STANDARDS COMPLIANCE	
ANSI/SIA A92.5	
CAN3-B354.4-M82	
CE compliance option	
AS 1418.10	

Features

STANDARD FEATURES

MEASUREMENTS

- S-120 has 38.4 m (126 ft) working height
- S-125 has 39.9 m (131 ft) working height
- 340 kg (750 lb) lift capacity on S-120
- 227 kg (500 lb) lift capacity on S-125

PRODUCTIVITY

- Four-wheel drive with four-wheel brakes
- Four-wheel steer includes front, rear, crab and coordinated steer functions
- Extendable axles, operated from platform
- 2.44 m (8 ft) steel platform
- Fully proportional platform controls with ramp up/down feature
- Hydraulic platform rotation
- 360° continuous turntable rotation
- 12V DC auxiliary power
- Closed-loop hydrostatic drive
- Positive traction drive
- Drive enable system
- Self-levelling platform
- Onboard full diagnostics
- Anti-restart engine protection
- Auto engine fault shutdown
- Hydraulic oil cooler
- Engine monitoring display
- Foam-filled tyres
- Wire braided hose
- Tilt alarm
- Horn
- Hour meter

POWER

- Deutz BF4L 2011 78 hp (58 kW)



OPTIONS & ACCESSORIES

PRODUCTIVITY

- Alarm package
- Cold start packages
- 5,000 watt AC generator
- Platform swing gate
- Air line to platform
- Platform rail pinch guard
- Platform work lights
- Hostile environment packages
- Tool tray
- Driving lights

ATTACHMENT OPTIONS

Genie has a large range of attachments available. Please contact Genie or your nearest dealer.

Genie Australia

591 Boundary Road, Darra, Qld 4076
PO Box 394, Richlands, Qld 4077
Tel: + 61 7 3375 1660
Toll Free In Australia: 1800 331 660
Fax: + 61 7 3375 1002

European Offices

UK

The Maltings
Wharf Road
Grantham NG31 6BH
UK
Tel: +44 (0)1476 584333
Fax: +44 (0)1476 584334

France

10, ZA de la Croix St. Mathieu
28320 Gallardon
France
Tel: +33 (0)2 37 26 09 99
Fax: +33 (0)2 37 26 09 98

Germany

Finienweg 3
28832 Achim/Bremen
Germany
Tel: +49 (0)4202 8852-0
Fax: +49 (0)4202 8852-25

Spain

Gai' a 31, Pol. Ind. Pl' a d'en Coll
08110 Montcada i Reixac
Barcelona
Spain
Tel: +34 93 572 50 90
Fax: +34 93 572 50 91

Scandinavia

Tagenevägen 72
425 37 Hisings Kärra
Sweden
Tel: +46 31 57 51 00
Fax: +46 31 57 90 20

Genie United States

18340 NE 76th Street
P.O. Box 97030
Redmond, Washington 98073-9730
USA
Tel: +1 425 881-1800
Fax: +1 425 883-3475

WEB: www.genieindustries.com.au

Distributed By: