

Z-34/22 IC

Self-Propelled Articulating Boom

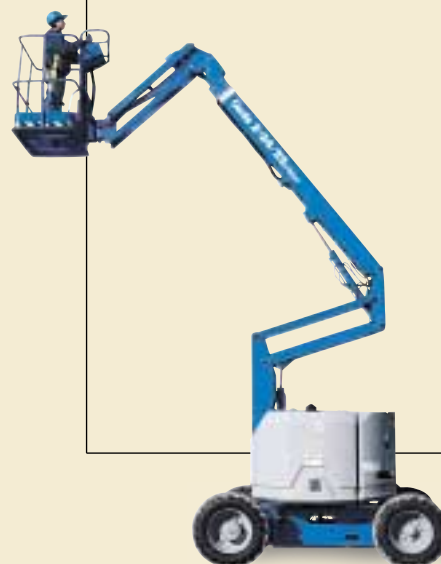

○ Unbeatable
engine package
for optimum
speed and
performance.



IC Series:

G/LPG4x2

D4x2

G/LPG4x4

D4x4

Genie Australia
GENIE MEANS MORE THAN LIFTING

Z-34/22 IC with Gas/LPG or Diesel power options.

- The Z-34/22 IC Series combines the **industry leading lift structure with an unbeatable engine package.**
- A new drive system, with a high quality axial piston pump and integrated controls, provides the **smooth control, durability and efficient power transmission required for rough terrain operation.**
- Two-speed hydraulic motors **provide optimum speed and torque.** The 4x2 model operates at **0-7.2 km/h (0-4.5 mph) with 37% gradeability.** The 4x4 model operates at **0-6.4 km/h (0-4 mph) with 45% gradeability.**
- Zero tailswing and nose swing in all positions, with a 1.73 m (68 in) wide 4x2 model and 1.78 m (70 in) wide 4x4 model, provide **excellent manoeuvrability in confined areas.**

▪ Dual parallelogram riser allows ascent and descent along a vertical plane without retraction or extension of the boom.

Standard Features

- 12.4 m (40 ft 8 in) working height
- 6.8 m (22 ft 4 in) horizontal reach
- Compact 1.73 m (68 in) wide 4x2 model and 1.78 m wide (70 in) 4x4 model
- 500 lb (227 kg) platform capacity
- 1.22 m (4 ft) jib features 144° working range
- Dual wheel spring-applied brakes
- Fully proportional controls
- 160° powered platform rotation
- Auxiliary power unit
- Drive enable system
- Self-levelling platform
- Water, oil and voltage gauges
- Hour meter
- Foam-filled tyres

Range of Motion

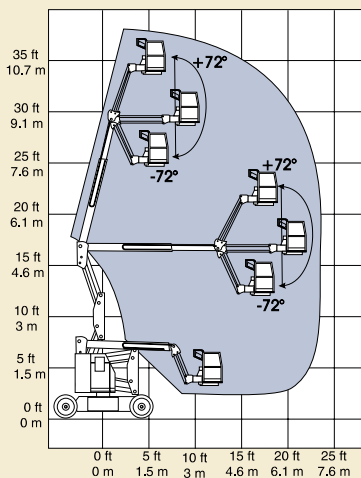

Options and Accessories

- Alarm package
- Cold start packages
- 2,000 watt AC generator
- 1.22 m (4 ft) platform
- Platform swing gate
- 10-16.5 rough terrain tyres for 4x2
- Industrial non-marking tyres
- Platform-mounted work light
- Air line to platform

Standards Compliance

- ANSI/SIA A92.5
- CE compliance option
- CSA/CAN3-B354.4-M82
- AS 1418.10

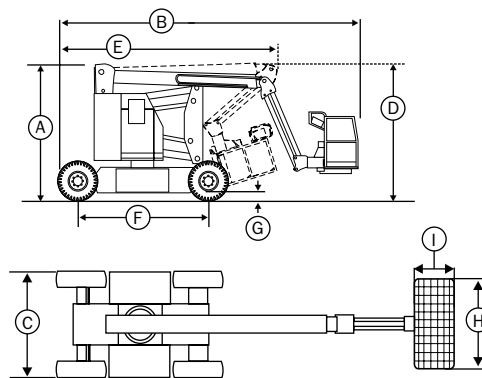

Specifications

Model	4x2	US	4x4	US
Working height	12.4 m	40 ft 8 in	12.4 m	40 ft 8 in
Platform height	10.6 m	34 ft 8 in	10.6 m	34 ft 8 in
(A) Height-stowed	2 m	6 ft 7 in	2 m	6 ft 8 in
(B) Length - stowed	5.6 m	18 ft 6 in	5.7 m	18 ft 7 in
(C) Width	1.73 m	5 ft 8 in	1.78 m	5 ft 10 in
(D) Storage height	2.26 m	89 in	2.29 m	90 in
(E) Storage length	4.1 m	13 ft 5 in	4.1 m	13 ft 6 in
(F) Wheelbase	1.88 m	6 ft 2 in	1.88 m	6 ft 2 in
(G) Ground clearance	15 cm	5 3/4 in	17 cm	6 1/2 in
(H) Platform width	1.42 m	56 in	1.42 m	56 in
(I) Platform length	76 cm	30 in	76 cm	30 in
Horizontal reach	6.8 m	22 ft 4 in	6.8 m	22 ft 4 in
Up and over clearance	4.6 m	15 ft	4.6 m	15 ft
Lift capacity	227 kg	500 lb	227 kg	500 lb
Turning radius - outside	4 m	13 ft 1 in	4 m	13 ft 1 in
Turning radius - inside	1.73 m	5 ft 8 in	1.73 m	5 ft 8 in
Turntable rotation	355°		355°	
Turntable tailswing	Zero		Zero	
Power source	Kubota G/LPG 18.3 kw (24.5 hp)		Kubota G/LPG 18.3 kw (24.5 hp)	
	Kubota Diesel 19.4 kw (26 hp)		Kubota Diesel 19.4 kw (26 hp)	
Drive speed-stowed	0-7.2 km/h	0-4.5 mph	0-6.4 km/h	0-4 mph
Drive speed - raised or extended	1 km/h	0.6 mph	1 km/h	0.6 mph
Extension speed	12.2 m/40 sec	40 ft/40 sec	12.2 m/40 sec	40 ft/40 sec
Controls	proportional		proportional	
Platform rotation	160°		160°	
Tyres	9-14.5 industrial		10-16.5 rough terrain	
Gradeability*	37%		45%	
Hydraulic tank capacity	68 litre	18 gal	68 litre	18 gal
Fuel tank capacity	44 litre	11.5 gal	44 litre	11.5 gal
Weight	4,763 kg	10,700 lb	4,854 kg	10,500 lb

*Stowed position only

Distributed By:

Genie Industries

GENIE AUSTRALIA

591 Boundary Road, Darra Qld 4076
 PO Box 394, Richlands Qld 4077
 Telephone **07 3375 1660**
 Toll Free in Australia **1800 331 660**
 Fax 07 3375 1002
 www.genielift.com

GENIE UNITED STATES

18340 NE 76th Street
 P.O. Box 97030
 Redmond, Washington 98073-9730
 Telephone **425 881 1800**
 Toll Free in USA/Canada **800 536 1800**
 Fax 425 883-3475
 www.genielift.com