



Rough Terrain Self-Propelled Scissor Lift

**GS™-4390 RT
GS™-5390 RT**

○ Ready to tackle the most rigorous job sites with superior gradeability and traction-controlled four-wheel drive.



GS™-4390 RT GS™-5390 RT

GS-4390 RT & GS-5390 RT

- Large platform with durable diamond-plate aluminium flooring. A single 1.52m (60 in) multi-position slide-out extension deck, on the front of the machine, comes standard. A second 1.22m (48 in) slide-out extension deck, on the rear of the machine, is available as an option.
- Rear platform railing can be removed for easier loading and unloading of materials.
- Slide-out engine tray allows easy access to components.
- Automatic levelling hydraulic outriggers are standard on both the GS-4390 RT and GS-5390 RT.

Standard Features

- GS-4390 RT has 14.9 m (49 ft) working height and GS-5390 RT has 18 m (59 ft) working height
- 680 kg (1,500 lb) load capacity
- Positive traction-controlled four-wheel drive
- 50% gradeability
- Proportional drive
- Two-speed lift functions
- Troubleshooting diagnostics
- Two self-closing entry gates
- Foam-filled tyres
- AC wiring to platform
- Descent alarm
- Tilt sensor with an audible alarm
- Horn
- Hour meter



Options and Accessories

- Motion alarm
- Dual flashing beacons
- Propane tank kit (single and/or additional)
- Dual slide-out extension deck package (front and rear)
- Hydraulic oil cooler
- 2,000 watt generator (110 volt/60 hz)

Standards Compliance

- ANSI/SIA A92.6
- CSA CAN3-B354.2-M82
- CE compliance option
- AS 1418.10

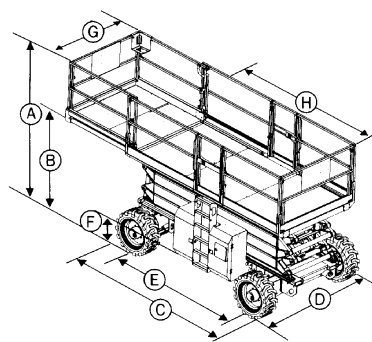

Specifications

Model	GS-4390 RT		GS-5390 RT	
	Metric	US	Metric	US
Working height	14.9 m	49 ft	18 m	59 ft
Platform height	13.1 m	43 ft	16.2 m	53 ft
(A) Height - stowed guardrails	2.93 m	115½ in	3.15 m	124 in
guardrails lowered	2.25 m	88¾ in	2.47 m	97¾ in
(B) Height - stowed (platform)	1.8 m	71 in	2.02 m	79½ in
(C) Length - stowed				
w/ single deck extension	3.94 m	155¾ in	n/a	n/a
w/ dual deck extension	3.98 m	156¾ in	n/a	n/a
w/ outriggers	4.88 m	192 in	4.88 m	192 in
(D) Width	2.29 m	90 in	2.29 m	90 in
(E) Wheelbase	2.92 m	115 in	2.92 m	115 in
(F) Ground clearance	36 cm	14 in	36 cm	14 in
(G) Platform width	1.83 m	72 in	1.83 m	72 in
(H) Platform length				
single deck extended	5.4 m	212½ in	5.4 m	212½ in
dual decks extended	6.57 m	258½ in	6.57 m	258½ in
Slide-out deck extension(s)				
standard front deck	1.52 m	60 in	1.52 m	60 in
optional rear deck	1.22 m	48 in	1.22 m	48 in
Lift capacity	680 kg	1,500 lb	680 kg	1,500 lb
Extension deck cap. (max)	227 kg	500 lb	227 kg	500 lb
Turning radius - outside	5.33 m	210 in	5.33 m	210 in
Turning radius - inside	2.16 m	85 in	2.16 m	85 in
Power source	Ford LRG 425 EFI Gas/LPG 61 kw (82 hp) Deutz Diesel 42 kw (56 hp)			
Auxiliary power unit	12V DC	12V DC	12V DC	12V DC
Drive speed - stowed	8 km/h	5 mph	8 km/h	5 mph
Drive speed - raised	1.1 km/h	0.7 mph	1.1 km/h	0.7 mph
Raise/lower speed	45 sec/39 sec		55 sec/49 sec	
Self-levelling capability				
w/outriggers side/side	12°		12°	
w/outriggers front/rear	7°		7°	
Controls	Two-speed lift and proportional drive			
Tyres	12-21.5 NHS foam filled			
Gradeability (4x4)	50%		50%	
Drive	four wheel			
Multiple disc brakes	dual rear wheel			
Fuel tank capacity	114 litre	30 gal	114 litre	30 gal
Hydraulic tank capacity	114 litre	30 gal	114 litre	30 gal
Weight	7,210 kg	15,896 lb	7,956 kg	17,540 lb

Distributed By:

Genie Industries™

GENIE AUSTRALIA

591 Boundary Road Darra Qld 4076
P.O. Box 394 Richlands Qld 4077
Telephone **07 3375 1660**
Toll Free in Australia **1800 331 660**
Fax 07 3375 1002
www.genielift.com

GENIE UNITED STATES

18340 NE 76th Street
P.O. Box 97030
Redmond, Washington 98073-9730
Telephone **425 881 1800**
Toll Free in USA/Canada **800 536 1800**
Fax 425 883 3475
www.genielift.com